



communications

**OPERATING and SERVICE
INSTRUCTIONS**



the hallicrafters co.

MANUFACTURERS OF ELECTRONIC EQUIPMENT, CHICAGO 24, U. S. A.



032-013508

Figure 1. Hallicrafters Model HT-41 Linear Amplifier.

GENERAL SPECIFICATIONS

| | |
|--|---|
| Mode of Operation | Grounded grid class B linear power amplifier. |
| Power Consumption | 1500 watts maximum, 117V, 60 cycles, AC. |
| Input Impedance | 40 ohms to 75 ohms. |
| Output Impedance | 40 ohms to 75 ohms. |
| Drive Power in Low Drive Position | 20 watts approximately. |
| Drive Power in High Drive Position | 60 watts approximately. |
| Overall Dimensions | 21-1/2 inches wide x 19 inches deep x 12-1/8 inches high. |
| Net Weight | 85 pounds. |
| Shipping Weight | 97 pounds. |

| | Plate Power Input | | |
|------------|-------------------|-----------|-----------|
| | SSB | *CW | AM |
| High Drive | 1200 watts PEP | 700 watts | 350 watts |
| Low Drive | 1000 watts PEP | 600 watts | 300 watts |

*In the High Drive position, it is permissible to run 900 watts input in Keyed CW operation (800 watts in Low Drive). The maximum Key down time shall not exceed 30 seconds under this condition of operation.

SECTION I

GENERAL

1-1. INTRODUCTION.

The Hallicrafters Model HT-41 is a linear amplifier using two RCA 7094 type tubes connected as high-mu triodes in grounded-grid class B operation. The equipment may be used on the 80-meter through 10-meter amateur bands. The Model HT-41 was designed as a companion unit for the Model HT-37 but may be used with the Model HT-32, FPM-200, or any 20-watt to 100-watt exciter without the need of an external pad or matching network.

The linear amplifier incorporates a heavy duty plate supply and employs two, type 866AX mercury vapor rectifiers. Excellent dynamic and static regulation is assured through the use of 17 microfarads of filter capacity and a wide-range swinging choke. A cut-off bias supply is included and provisions have been made for applying cut-off bias when the Model HT-41 is properly connected to the exciter VOX circuit.

The broad-band, low-impedance (40 ohms to 75 ohms), input circuit eliminates the necessity of input tuning, making neutralization unnecessary on any frequency within the operating range. This also makes the operation of the amplifier extremely stable.

A heavy duty, optimum "Q," multitap, pi-network, output circuit allows maximum power to be transferred into any antenna load ranging from 40 ohms to 75 ohms.

1-2. TVI (TELEVISION INTERFERENCE) SUPPRESSION.

Every consideration has been given to minimizing possible local TVI problems in the design of the Model HT-41. The unit incorporates a brute force, low-pass line filter, full RF bypassing, and shielding. A ground lug has been provided at the rear of the chassis for an external ground connection. It is recommended that all station components be bonded together with heavy copper wire or strap and connected to an earth ground. Ground leads, which are equal to multiples of one-quarter wavelengths at your favorite operating frequencies, should be avoided.

NOTE

With any high power installation, particularly in fringe reception areas, TVI may be a problem. Should this occur, it is recommended that a high quality, low pass filter be used.

1-3. ADDITIONAL FEATURES.

Many additional features are included in the Model HT-41 for reliability and ease of operation. All important circuits are metered by means of a three-position meter switch and an easily read, illuminated, front panel meter. In addition to reading grid current and plate current, the meter measures RF output for easier tuning. In this position, both the plate and output TUNING controls are adjusted for maximum indicated RF output voltage. A green lamp on the front panel indicates that power is applied to the filaments, bias supply, and fan. A red lamp on the front panel indicates that the high voltage supply is on. All band switching is accomplished by a single knob.

SECTION II

INSTALLATION

2-1. UNPACKING.

When removing the unit from the carton, do not attempt to lift it by the cover. After unpacking the amplifier, examine it carefully for any possible damage which may have occurred during transit. Should any sign of damage be apparent, file a claim immediately with the carrier stating the extent of damage. Check all shipping tags and labels for special instructions before removing or destroying

them. All tubes are contained in a separate carton to prevent damage to the tubes during shipment.

NOTE

Remove each tube from its carton only when you are ready to install it. **DO NOT USE FORCE** when inserting tubes in sockets.

Remove the top cover of the amplifier by unscrewing the four side screws and then lifting the cover completely off the unit. Remove one of the type 866AX rectifier tubes from the carton and locate the four-prong tube sockets. Insert the tube into one of these sockets so that the two larger pins engage the two larger pins openings. When the pins engage the socket, press down lightly until the tube is seated firmly in place.

Connect the plate transformer lead, located directly behind the inserted tube, to the plate cap of the tube. Remove the remaining type 866AX tube from its carton and insert it into the other four-prong socket the same as above. Connect the remaining plate transformer lead to the plate cap of this tube.

Remove one of the type 7094 tubes from its carton and locate the recessed tube sockets directly in front of the fan. Insert the tube in one of these sockets, the largest pin on the tube into the corresponding largest pin opening on the socket. When the tube engages the tube socket, press down lightly until the tube is firmly seated in the socket. **DO NOT USE FORCE.** Connect the plate cap (heat radiating), which is connected to the parasitic suppressor located directly in front of the tube, to the plate pin on top of the type 7094 tube. Tighten the holding screw on the plate cap firmly, but **DO NOT USE FORCE.**

Remove the remaining type 7094 tube from its carton and install it into the remaining 7094 socket. When installing this tube, use the same procedure as above.

Replace the top cover and secure with the four side screws.

2-2. LOCATION.

It is very important that the amplifier be placed in such a manner that complete air circulation is available on all four sides, the top, and the bottom. The air intake for the fan is situated at the rear of the top cover. Sufficient air space must be maintained around the unit. Under no circumstances should any object be placed on the top of the amplifier; the warm air is exhausted through the top.

2-3. POWER REQUIREMENTS.

The Model HT-41 Linear Amplifier is designed to operate from a 117-volt, 60-cycle, power source. The source must be capable of supplying 1500 watts with good regulation at the specified line voltage if maximum capabilities are to be realized.

NOTE

If in doubt about your power source, contact your local power company prior to inserting the power cord into an AC power outlet. Plugging the power into the wrong power source can cause extensive damage to the unit, requiring costly repairs.

2-4. RF INPUT AND OUTPUT CONNECTIONS.

A. RF INPUT. - The input connector, located at the rear of the chassis, will mate with a type PL-259 coaxial connector (Amphenol Type 83-1 SP). The output of the exciter should be applied through this connector. The input of the amplifier is designed for an input impedance of 40 ohms to 75 ohms.

IMPORTANT

For best performance, the input cable length should be less than $1/4$ wavelength on the highest operating frequency.

When the linear amplifier is used with exciters having less than 60 watts output, a jumper should be placed between the screw terminals on the "Drive Level" strip. (See Figure 3)

It should be noted that the efficiency will be reduced under this condition of operation; therefore, the ratings given under SPECIFICATIONS should be adhered to.

B. RF OUTPUT. - The output connector, located at the rear of the chassis, will mate with a type PL-259 coaxial connector (Amphenol Type 83-1 SP). Use only RG-8/U coaxial cable for the output feed line. Although the load impedance is variable, it is recommended that the load be 50 ohms with the lowest possible VSWR.

2-5. BIAS AND ANTENNA RELAY CONNECTIONS

It is recommended that coaxial-type antenna changeover relays be used with the Model HT-41 Linear Amplifier.

Cut-off bias should be used in all modes of operation. Figure 2 illustrates how to connect the antenna and bias switching circuits. The Model HT-41 is shipped without a jumper connected between the screw terminals of the cut-off bias terminal strip.

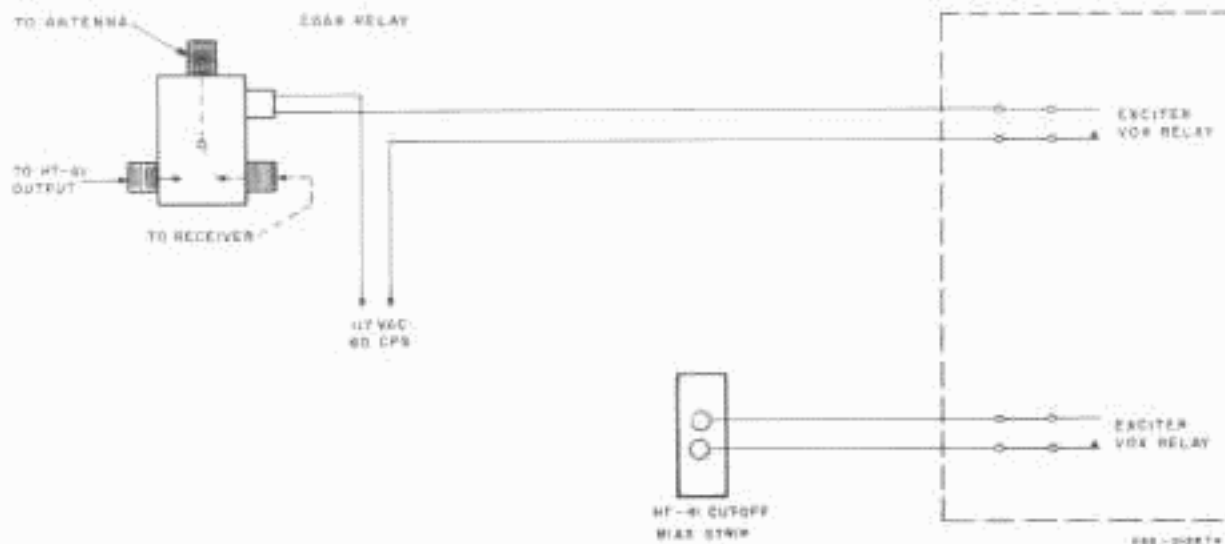

Figure 2. Antenna and Bias Switching Circuit.

SECTION III

FUNCTION OF OPERATING CONTROLS

3-1. FILAMENT SWITCH.

The FILAMENT switch, a two-position toggle switch, applies power to the filaments, fan, and cut-off bias supply.

3-2. PLATE VOLTAGE SWITCH.

The PLATE VOLTAGE switch, a two-position toggle switch, applies power to the high voltage supply.

3-3. METER SWITCH.

The METER SWITCH, a three-position wafer switch, selects the desired circuit to be monitored.

The operator may select grid current, plate current, or RF output voltage.

3-4. BAND SELECTOR.

The BAND SELECTOR switch, a six-position wafer switch, selects the desired amateur band. This switch places a short across the unused portion of the tank coil and switches in additional loading capacitance on the 40, 75, and 80-meter bands.

3-5. PLATE TUNING.

The plate TUNING control, a variable capacitor, resonates the plate circuit at the desired frequency.

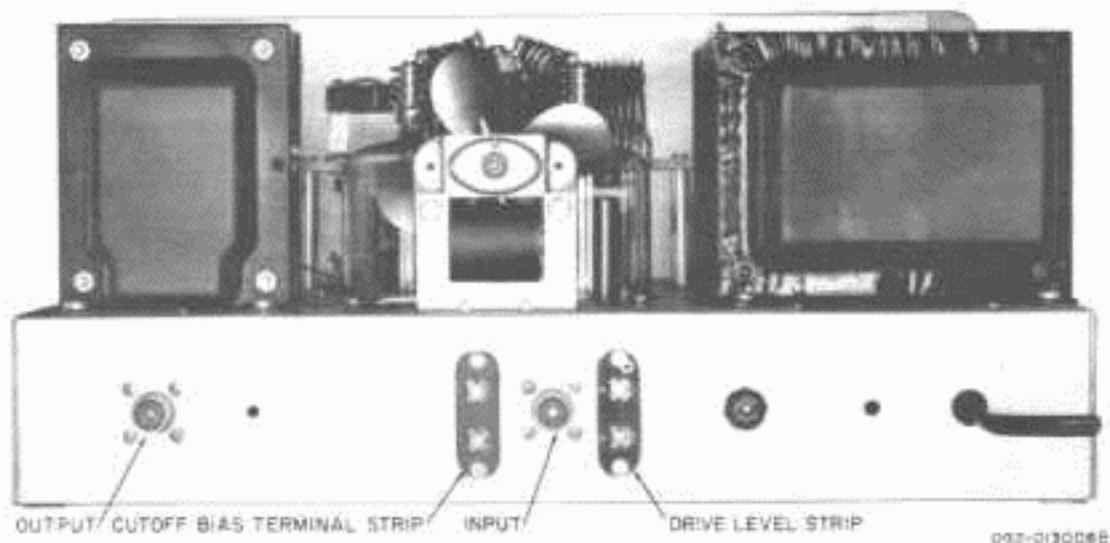

Figure 3. Rear View of Chassis

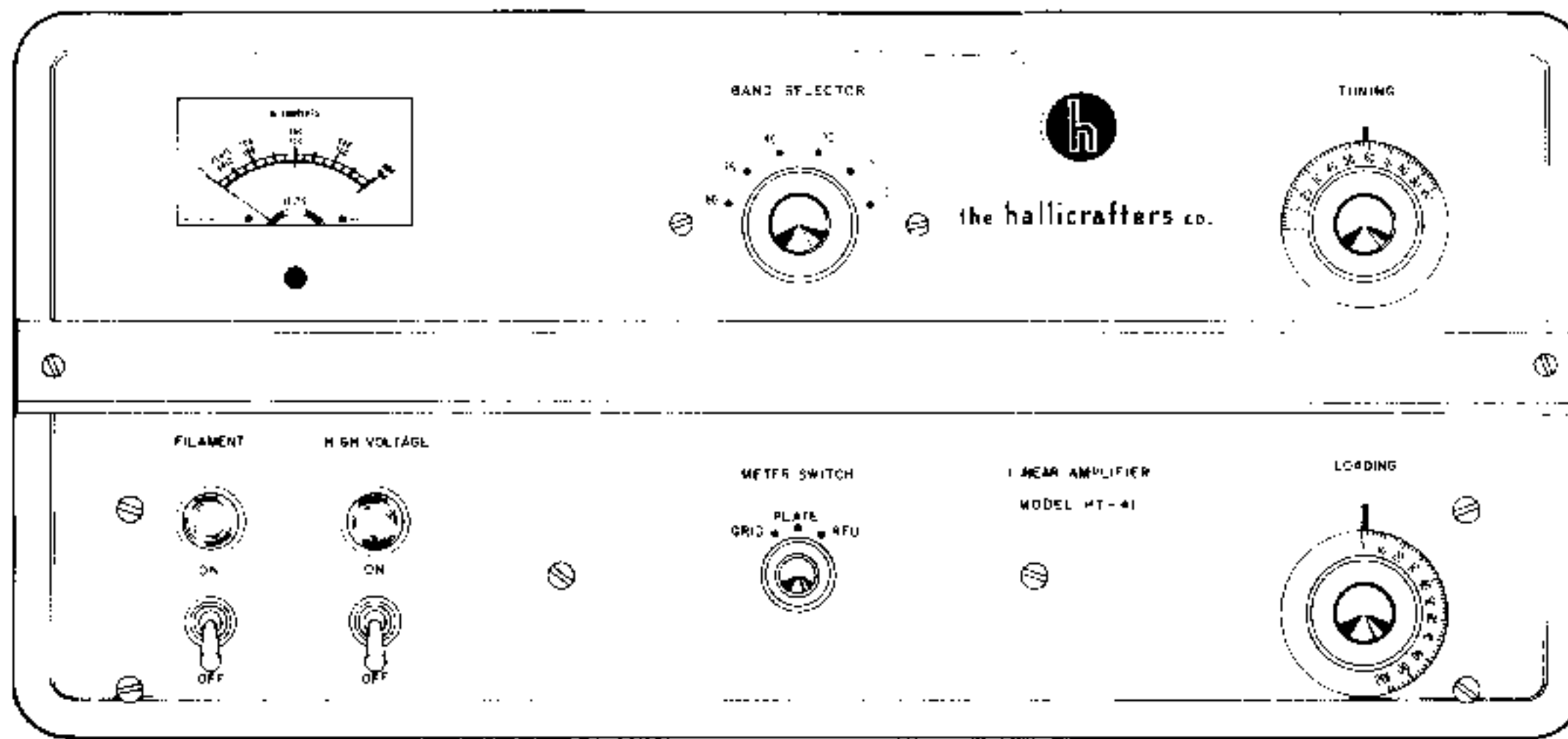

Figure 4. Front Panel Controls

3-6. PLATE LOADING.

The plate LOADING control, a variable capacitor, adjusts the output impedance to the antenna load impedance (40 ohms to 75 ohms).

3-7. METER

The meter provides an accurate indication for tuning the amplifier. The meter indicates grid current (0 to 400 MA), plate current (0 to 800 MA), and RF output voltage (0 to 400V).

SECTION IV

OPERATING PROCEDURE

4-1. GENERAL.

When tuning the Model HT-41, it is important that both the plate TUNING and plate LOADING controls are adjusted for maximum RF output as indicated on the RF output voltmeter.

NOTE

Power input should always be a direct function of the applied excitation. Never attempt to control the power input with the loading adjustments.

A monitor oscilloscope should be used for best results in all modes of operation, (especially SSB, AM, and DSB), as the one-quarter second meter (FCC requirement) will not follow voice peaks and, of course, in no way indicates true power input under voice operations.

Some of the many factors which influence the indicated power input are the degree of damping in the meter, individual voice characteristics, microphone frequency response characteristics, exciter audio bandwidth response, etc.

In normal SSB operation, the plate current meter will indicate approximately 300 MA on voice peaks (High Drive). If the Low Drive position is used, the plate current meter will indicate approximately 250 MA on voice peaks.

Before attempting to operate the Model HT-41, the following items should be checked:

1. All station components should be bonded together and connected to an earth ground.
2. The output should be connected to a 50-ohm antenna load through an RG-8/U transmission line. **NEVER OPERATE THE MODEL HT-41 WITHOUT A LOAD.**
3. The input should be connected to the exciter through the coaxial cable. For best results, this cable should be less than a one-quarter wave length long at the highest operating frequency.
4. The cut-off bias terminals on the screw type terminal strip should be connected to the exciter, as shown in figures 2 and 3.
5. The FILAMENT and plate switch should be in the OFF position.

CAUTION

NEVER CONNECT THE MODEL HT-41 TO AN AC LINE WHEN THE ABOVE SWITCHES ARE IN THE ON POSITION.

4-2. TUNING PROCEDURE.

The following procedure applies to all modes of operation:

1. Place the FILAMENT switch in the ON position to apply voltage to the green pilot lamp, the tube filaments, the bias supply, and the fan.

NOTE

Allow four minutes minimum filament warmup time before applying plate voltage.

2. Set the BAND SELECTOR switch to the desired band.

3. Set the METER SWITCH to PLATE.

4. Place the HIGH VOLTAGE switch in the ON position.

4-3. CW OPERATION (High Drive).

1. Assuming the filament and plate voltages have been applied, carefully increase the CW output on the exciter until the plate meter on the Model HT-41 reads approximately 150 MA.

2. Turn the METER SWITCH on the Model HT-41 to RFO and adjust the plate TUNING and plate LOADING controls for maximum upward deflection on the meter.

3. Set the METER SWITCH to PLATE and again increase the exciter's output until the Model HT-41 plate current reads approximately 300 MA.

4. Set the METER SWITCH to RFO and again adjust the plate TUNING and plate LOADING for maximum upward meter deflection.

5. Set the METER SWITCH to PLATE and increase the exciter's output until the Model HT-41 plate current reads 400 MA.

6. Set the METER SWITCH to RFO and again adjust the plate TUNING and plate LOADING controls for maximum upward meter deflection. If the plate current meter indicates 400 MA with the plate TUNING and plate LOADING controls adjusted for maximum RFO upward meter deflection, the amplifier is correctly loaded for 700 watts average DC input.

7. If it is desired to operate the Model HT-41 at the 900-watt input level, the exciter's output should be increased until the plate current meter indicates 500 MA with the plate TUNING and plate LOADING controls adjusted for maximum RFO upward meter deflection.

CAUTION

If the plate current is increased beyond 400 MA, as in step 7, the tuning adjustments should be made as rapidly as possible. Excitation should not be applied at the 500 MA level for more than 30 seconds.

If the Low Drive position is used (that is, with the jumper across the drive level terminal strip and the exciter with less than 60 watts output), the tuneup procedure will be the same as described in steps 1 through 5. However, the last plate TUNING and plate LOADING control adjustment is to be made at 335 MA plate current (600 watts input).

If it is desired to operate at the 800-watt input level using the Low Drive, the last plate TUNING and plate LOADING control adjustments should be made at 450 MA plate current (800 watts input).

CAUTION

If the plate current is increased beyond 335 MA in Low Drive, the tuning adjustments should be made as rapidly as possible. Excitation should not be applied at the 450 MA level for more than 30 seconds.

4-4. SSB OPERATION (High Drive)

1. Follow steps 1 through 7 as described in paragraph 4-3.

2. Switch the exciter to the SSB position and adjust the microphone gain until the Model HT-41 plate current meter indicates approximately 300 MA on voice peaks, or until flat-topping is indicated on a monitor oscilloscope.

NOTE

If the Low Drive position is used, the tuneup procedure will be the same as described above except that the last plate TUNING and plate LOADING control adjustment is to be set at 450 MA plate current (See Low Drive CW).

The exciter microphone gain should be adjusted to the point where the Model HT-41 plate current meter indicates approximately 250 MA on voice peaks, or until flat-topping occurs on a monitor oscilloscope.

4-5. AM OPERATION (High Drive).

1. Adjust the Model HT-41 plate TUNING and plate LOADING controls as described in steps 1 through 7 of paragraph 4-3.

2. Switch the exciter to the AM(DSB) position and adjust the exciter output until the Model HT-41 plate current meter indicates 200 MA. There will be a slight change in plate current with modulation.

NOTE

If Low Drive position is used, the loading adjustments will be the same as described for the Low Drive SSB procedure previously described. The exciter output should be adjusted so that the Model HT-41 plate current will be 170 MA.

4-6. CALCULATING POWER INPUT.

Round numbers have been used in the loading instructions. To determine the average DC plate

power input, multiply the plate current by 1800 volts (500 MA x 1800 volts = 900 watts).

Meter readings will be accurate only when steady CW input is being measured. As previously mentioned, many factors influence the indicated plate current on SSB. Therefore, no meter can give a true indication of the plate power input on SSB.

NOTE

On some frequencies at low power levels, the plate LOADING control may not reach a definite peak during the process of loading. Should this condition occur, leave the plate LOADING control at the point which gives the greatest RFO indication and continue to the next loading step described in the above procedure. This condition will rectify itself at normal operating levels.

SECTION V

SERVICE DATA

5-1. WARNING HIGH VOLTAGE.

DC voltages in excess of 2000 volts are present in this equipment. DO NOT attempt to measure voltages with hand-held test leads or to service this amplifier with the high voltage supply on. In addition to the danger of serious injury or death from the high voltage supply, serious radio frequency burns can be caused by coming in contact with, or in close proximity to, the plate and output circuits.

CAUTION

Use extreme caution when working with this equipment.

5-2. CLEANING.

Equipment that is power-cooled may tend to collect dust within the unit, depending on the content of the air being circulated.

All components should be kept clean, as any accumulation of dust in the high voltage or RF areas may cause arcing and consequent damage. This applies to the top, bottom, and sides of the chassis. Both the plate tuning and loading capacitors should be cleaned frequently to prevent arcing between plates.

CAUTION

Do not nick or bend capacitor plates. Never use solvents for cleaning. The preferred method of cleaning is the use of a vacuum cleaner while dusting with a clean, flexible, bristle brush.

5-3. LUBRICATION.

Both the front and rear fan bearings should be lubricated with SAE No. 10 oil. This can be accomplished by saturating the felt storage pads with oil twice a year.

5-4. SERVICE OR OPERATION QUESTIONS.

For further information regarding operation or servicing of the Model HT-41 Linear Amplifier, contact your Hallicrafters dealer.

The Hallicrafters Company maintains an extensive system of Authorized Service Centers where any required service will be performed promptly and efficiently at a nominal charge. All Hallicrafters Authorized Service Centers display the sign shown on next page. For the location of the one nearest you, consult your dealer or telephone directory. Make no service shipments to the

factory unless instructed to do so by letter, as The Hallicrafters Company will not accept the responsibility for unauthorized shipments.

The Hallicrafters Company reserves the privilege of making revisions in current production of equipment and assumes no obligation to incorporate these revisions in earlier models.



SECTION VI

SUPPLEMENTARY DATA

6-1. NEUTRALIZATION.

No neutralization is necessary. Grounded grid operation, low impedance input, and excellent shielding and bypassing assures complete stability at all times.

6-2. GRID CURRENT.

Grid current will be approximately 80 MA to 100 MA on SSB voice peaks. Under no circumstances should the grid current be allowed to exceed 200 MA maximum.

NOTE

Grid excitation should always be removed from the amplifier before the HIGH VOLTAGE switch is placed in the OFF position.

6-3. IDLING PLATE CURRENT.

The Model HT-41 will have an indicated idling plate current of approximately 85 MA when bias is not applied.

6-4. PLATE CURRENT.

The indicated plate current on SSB voice peaks (High Drive) 1200 watts PEP input will be approximately 300 MA.

Low Drive - 250 MA will be 1000 watts PEP.

6-5. PLATE VOLTAGE.

The plate voltage will be approximately 1800 volts with a 400-MA load at 117 volts AC input.

6-6. RF OUTPUT VOLTMETER.

This voltmeter is connected across the output coaxial cable and indicates maximum output voltage. This meter is not accurately calibrated and is to be used as a tuning indicator (always tune for maximum voltage readings for a given plate current). As this is not a peak reading voltmeter, voice peaks will deflect the meter approximately one-third of the equivalent CW output.

6-7. TUBE COOLING.

A small cooling fan is included in the unit to keep the tubes and related parts within their rated temperature limits. Never operate the amplifier if the cooling fan is inoperative.

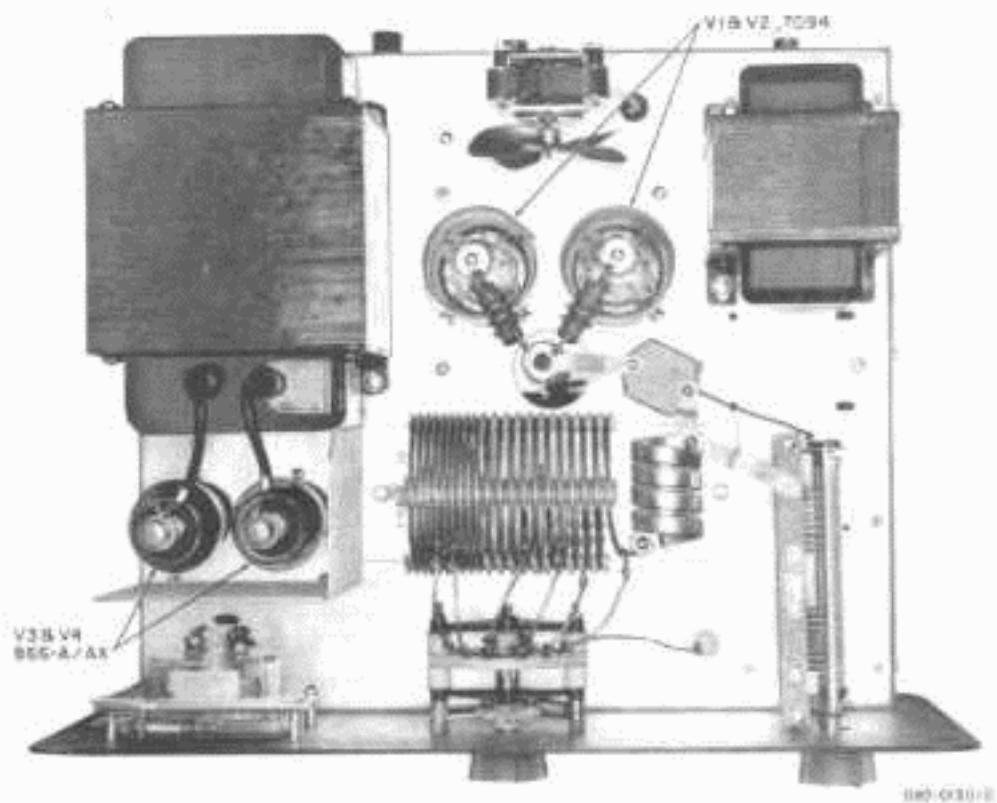

Figure 5. Top View of Chassis.

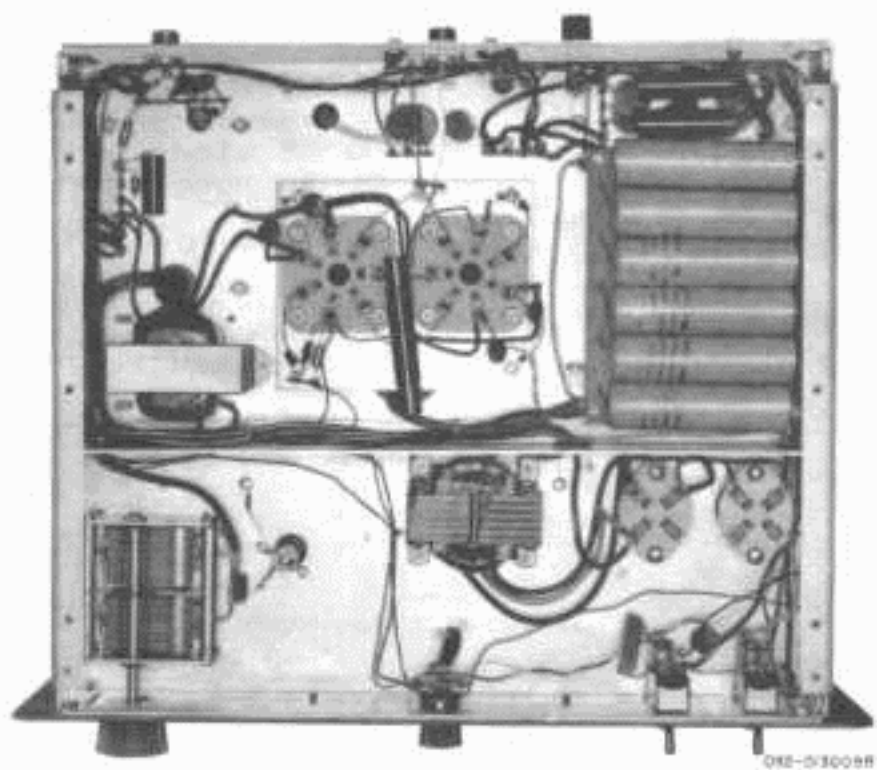

Figure 6. Bottom View of Chassis.

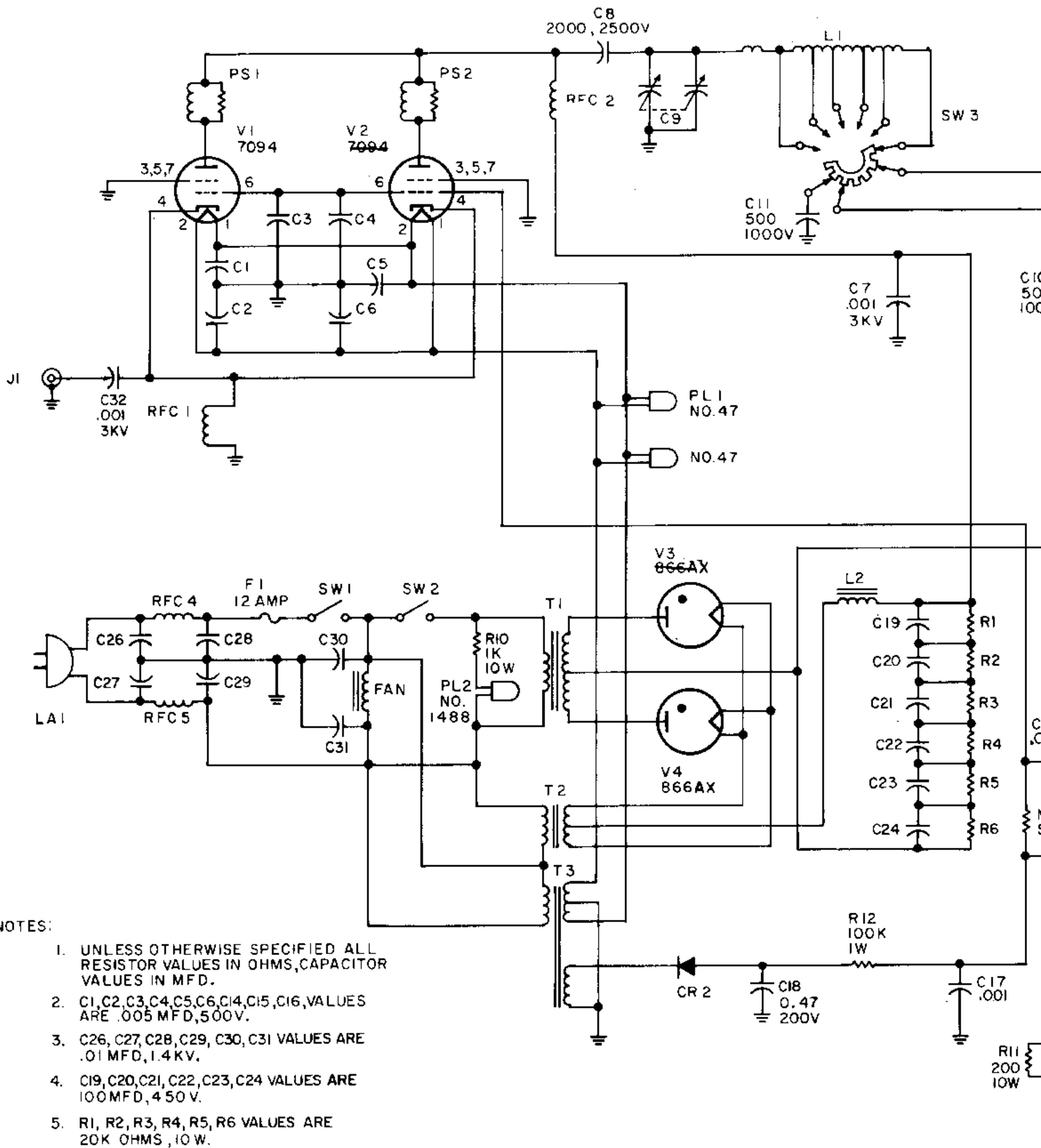
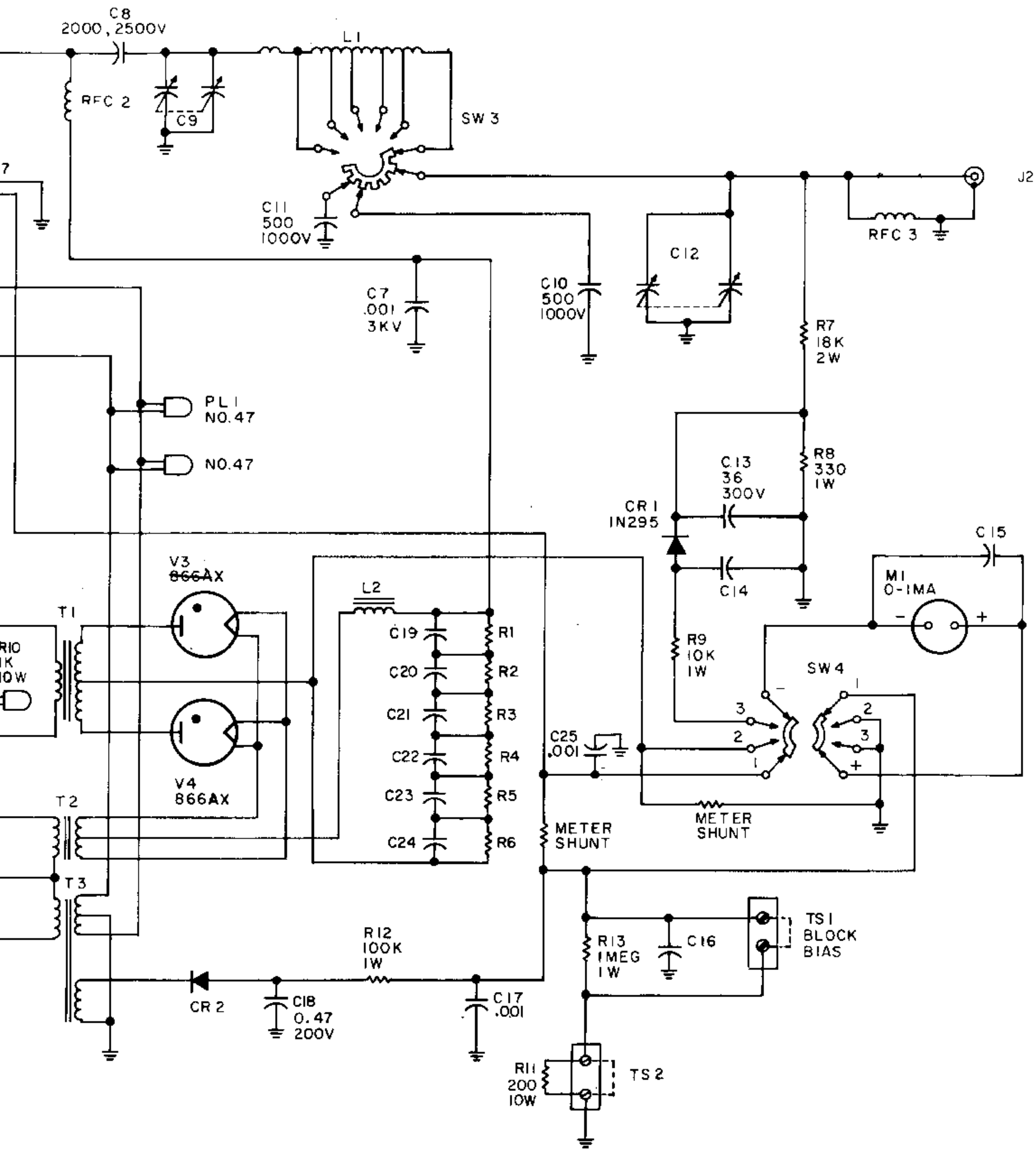

Figure 7. Schematic Diagram for HT-41 Linear Amplifier.



089-002738

Figure 7. Schematic Diagram for HT-41 Linear Amplifier.

SERVICE PARTS LIST

| Schematic Symbol | Description | Hallcrafters Part Number | Schematic Symbol | Description | Hallcrafters Part Number |
|-------------------------------|----------------------------------|--------------------------|--|----------------------------------|--------------------------|
| CAPACITORS | | | COILS AND TRANSFORMERS (Cont.) | | |
| C1,2,3,4,5,6,14,15,16 | 0.005 mfd., 500V, Cer. Disc | 047-100168 | T3 | Transformer Filament and Bias | 052-000889 |
| C7,32 | 0.001 mfd., 3KV, 20% Cer. Disc | 047-100397 | SWITCHES | | |
| C8 | 0.002 mfd., 2500 WVDC, 10% Mica | 470-943202 | SW1,2 | Switch, Toggle, DPST | 060-002276 |
| C9 | Variable Capacitor, PLATE TUNING | 048-000507 | SW3 | Switch, Rotary; BAND SELECTOR | 060-002274 |
| C10,11 | 500 mmf., 1000 WVDC, 5% Duramica | 493-410501-244 | SW4 | Switch, Rotary; METER | 060-002347 |
| C12 | Variable Capacitor, LOADING | 048-000527 | KNOB AND SKIRTS ASSEMBLIES | | |
| C13 | 36 mmf., 300V, 10% Duramica | 481-153360 | | Knob, TUNING and LOADING | 015-001723 |
| C17,25 | 0.001 mfd., 500V, Cer. Disc | 047-200230 | | Knob, METER SWITCH | 015-001725 |
| C18 | 0.47 mfd., 200V, 20% Mylar | 046-001302-05 | | Knob, BAND SELECTOR | 015-001722 |
| C19,20,21,22,23,24 | 100 mfd., 450V, Electrolytic | 047-000783 | TUBES, LAMPS, RECTIFIERS AND DIODES | | |
| C26,27,28,29,30,31 | 0.01 mfd., 1400V, Cer. Disc | 047-200752 | V1,2 | Tube, RF Amplifier 7094 | 090-001445 |
| RESISTORS | | | V3,4 | Tube, Rectifier 866AX | 090-901185 |
| R1,2,3,4,5,6 | 20K ohm, 10%, 10W, W.W. | 445-032203 | PL1 | Lamp, Pilot No. 47 | 039-100004 |
| R7 | 18K ohm, 10%, 2W | 451-652183 | PL2 | Lamp, Pilot No. 1488 | 039-100497 |
| R8 | 330 ohm, 10%, 1W | 451-352331 | CR1 | Diode, Germanium 1N295 | 019-301980 |
| R9 | 10K ohm, 10%, 1W | 451-352103 | CR2 | Diode, Silicon | 019-002798 |
| R10 | 1K ohm, 10%, 10W | 445-032102 | MISCELLANEOUS | | |
| R11 | 200 ohm, 10%, 10W, W.W. | 024-001390 | | Blade, Fan | 080-000782 |
| R12 | 100K ohm, 10%, 1W | 451-352104 | | Cabinet, Bottom | 066-702447 |
| R13 | 1 megohm, 10%, 1W | 451-352105 | | Cabinet, Top | 066-003168 |
| COILS AND TRANSFORMERS | | | | Cap, Plate | 076-100008 |
| L1 | Coil, Tank Final Plate | 051-003159 | F1 | Fuse (12 amp, 250V, 3AB) | 039-100497 |
| L2 | Choke, Swinging | 056-000457 | | Fuse Holder | 006-100451 |
| PS1,2 | Choke, Parasitic <i>47u</i> | 053-000655 | J1,2 | Connector, Coaxial | 010-100056 |
| RFC1 | Choke, RF Cathode | 053-300276 | LA1 | Line Cord | 087-104690 |
| RFC2 | Choke, RF Plate | 053-000624 | M1 | Meter | 082-000531 |
| RFC3 | Choke, RF Safety | 053-200444 | | Motor, Fan | 020-000321 |
| RFC4,5 | Choke AC Line | 053-000628 | | Panel, Front | 068-001178 |
| T1 | Transformer High Voltage | 052-000884 | | Board, Printed Circuit | 129-000553 |
| T2 | Transformer Filament | 052-000892 | | Socket Ass'y Pilot Light (Red) | 086-000562 |
| | | | | Socket Ass'y Pilot Light (Green) | 086-000571 |
| | | | | Connector, Heat Radiating | 076-003622 |
| | | | | Lock Ling Cord | 076-100953 |
| | | | | Trim Strip | 007-000815 |

K4XL's **BAMA**

This manual is provided **FREE OF CHARGE** from the “BoatAnchor Manual Archive” as a service to the Boatanchor community.

It was uploaded by someone who wanted to help you repair and maintain your equipment.

If you paid anyone other than BAMA for this manual, you paid someone who is making a profit from the free labor of others without asking their permission.

You may pass on copies of this manual to anyone who needs it. But do it without charge.

Thousands of files are available without charge from BAMA. Visit us at <http://bama.sbc.edu>